

TECHNICAL INFORMATION



PRODUCT

P 1 / 16

Model No. ▶ 4340T

Description ▶ Jig Saw

CONCEPT AND MAIN APPLICATIONS

The above mentioned jig saw is the advanced version of the existing model 4304Tseries.

Its brief benefits and features are

- * New tool less blade change system
- * Incredibly low vibration and noise level

Dimensions : mm (")	
Length (L)	236 (9-1/4)
Height (H)	204 (8)
Width (W)	73 (2-7/8)

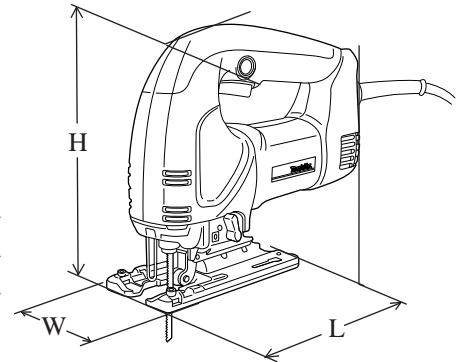

► Specification

Voltage (V)	Current (A)	Cycle (Hz)	Continuous Rating (W)		Max. Output(W)
			Input	Output	
220	2.8	50 / 60	580	300	550
230	2.7	50 / 60	580	300	550
240	2.5	50 / 60	580	300	550

Strokes per min. : spm.= min.-1		2,800	
Length of Stroke : mm (")		26 (1)	
Blade shank	BOSCH Type	Yes	
	MAKITA Type		
Orbital action of blade		Yes / 3 stages	
Max. cutting capacities : mm (")	Wood	for Europe	110 (4-5/16)
		Except Europe	* 135 (5-5/16)
	Mild Steel		10 (3/8)
	Aluminum		20 (25/32)
Protection from electric shock		by double insulation	
Net weight : Kg (lbs.)		2.4 (5.3)	
Cord length : m (ft)		2.5 (8.2)	

* With attaching jig saw blade No. B-16L(optoinal accessory),

► Standard equipment

- * Jig saw blade set (including B-10: 2 pcs., BR-13: 2 pcs., B-22: 2 pcs.)..... 1 set
- * Cover plate 1 pc.
- * Kerf board 1 pc.
- * Hex wrench 1 pc.
- * Dust nozzle (only for Europe) 1 pc.
- * Plastic carrying case 1 pc.

< Note > The standard equipment for the tool shown may differ from country to country.

► Optional accessories

- | | | | |
|-----------------------|-------------------------|-------------------------|--------------------------|
| * Guide rule | * Jig saw blade No.B-8 | * Jig saw blade No.B-17 | * Jig saw blade No.B-26 |
| * Guide rail set | * Jig saw blade No.B-10 | * Jig saw blade No.B-18 | * Jig saw blade No.B-27 |
| * Guide rail adaptor | * Jig saw blade No.B-11 | * Jig saw blade No.B-19 | * Jig saw blade No.B-16L |
| * Kerf board | * Jig saw blade No.B-12 | * Jig saw blade No.B-21 | * Jig saw blade No.BR-13 |
| * Dust nozzle | * Jig saw blade No.B-13 | * Jig saw blade No.B-22 | * Plastic base plate |
| * Hose | * Jig saw blade No.B-14 | * Jig saw blade No.B-23 | |
| * Jig saw blade No.51 | * Jig saw blade No.B-15 | * Jig saw blade No.B-24 | |
| * Jig saw blade No.58 | * Jig saw blade No.B-16 | * Jig saw blade No.B-25 | |