

LEVANO® I  
REF. 513000



LEVANO® II  
REF. 514000



- F NOTICE D'INSTRUCTIONS ET DE MAINTENANCE
- GB INSTRUCTIONS AND MAINTENANCE MANUAL
- D BEDIENUNGS-UND WARTUNGSANLEITUNG
- NL GEBRUIKS-EN ONDERHOUDSAANWIJZING
- I AVVERTENZE, ED ISTRUZIONI, PER LA MANUTENZIONE
- E MANUAL DE INSTRUCCIONES Y MANTENIMIENTO

F

**DECLARATION DE CONFORMITE**

Le constructeur, Roger MONDELIN S.A.S. ZI Le Maroquin F-42820 AMBIERLE déclare que le matériel neuf désigné ci-après :  
**LEVANO® I Réf. 51.300.0 – Elévateur manuel utilisé pour la pose de plaque de plâtre**  
Est conforme à la directive européenne 2006/42/CE du 17 mai 2006.

Un examen de conformité a été réalisé par SOCOTEC, organisme extérieur à l'entreprise. (Procès-verbal N° 303F0/11/1619)  
La présentation, de la présente déclaration de conformité, ne dispense les utilisateurs et les chefs d'établissement utilisateurs, de leurs obligations quand les exigences réglementaires du pays, dans lequel ce produit est mis en œuvre, l'exigent.

GB

**DECLARATION OF CONFORMITY**

The manufacturer, Roger MONDELIN S.A.S. ZI Le Maroquin F-42820 AMBIERLE certifies that the new equipment designated  
**LEVANO® I Réf. 51.300.0 – Manual lifting device used to fix plasterboard panels**  
Is in conformity with the European directive 2006/42/EC of May 17, 2006.

Conformity control made by SOCOTEC. Report No. 303F0/11/1619  
The presentation of this declaration of conformity does not free the users and company managers from their obligations, when the regulations of the country in which this product is implemented require it

D

**ÜBEREINSTIMMUNGSERKLÄRUNG**

Der Hersteller, Roger MONDELIN S.A.S. ZI Le Maroquin F-42820 AMBIERLE erklärt, daß das nachfolgend bezeichnete, neue Gerät :

**LEVANO® I Réf. 51.300.0 – Handbetätigte Hubvorrichtung zum Verlegen von Gipsplatten**  
Mit der europäischen Richtlinie 2006/42/EG vom 17. Mai 2006 in Übereinstimmung ist.

Übereinstimmungstest, der durch SOCOTEC durchgeführt wurde. Bericht Nr. 303F0/11/1619  
Die Präsentation der vorliegenden Konformitätserklärung befreit die Anwender und Betriebsleiter nicht von ihren Pflichten, wenn die Regelungen des Landes, in welchem dieses Produkt benutzt wird, es verlangen.

NL

**CONFORMITEITSVERKLARING**

De fabrikant, Roger MONDELIN S.A.S. ZI Le Maroquin F-42820 AMBIERLE verklaart dat nieuw materieel met volgende benaming :

**LEVANO® I Réf. 51.300.0 – Manuele lift bestemd voor het plaatsen van gipsplaten**  
Is conform aan de Europese richtlijn 2006/42/EG van 17 mei 2006.

Conformiteitsattest afgeleverd door SOCOTEC. Rapport Nr. 303F0/11/1619  
Het voorleggen van onderhavige conformiteitsverklaring stelt de gebruikers en de ondernemingsleiders van gebruikers met vrij van hun verplichtingen als de reglementering van het land waar het product wordt gebruikt dat vereist.

I

**DICHIARAZIONE DI CONFORMITÀ**

Il costruttore, Roger MONDELIN S.A.S. ZI Le Maroquin F-42820 AMBIERLE, dichiara che il materiale nuovo in appresso designato :

**LEVANO® I Réf. 51.300.0 – Elevatore manuale da utilizzare per la posa di lastre di gesso**  
è conforme alla direttiva europea 2006/42/CE del 17 Maggio 2006.

Esame di conformità realizzato da SOCOTEC. Relazione numero 303F0/11/1619  
La presentazione di questa dichiarazione di conformità non dispensa gli utilizzatori e i responsabili delle ditte utilizzatrici dal rispetto degli obblighi imposti dai regolamenti specifici in vigore nella nazione di utilizzo del prodotto.

E

**DECLARACIÓN DE CONFORMIDAD**

El constructor, Roger MONDELIN S.A.S. ZI Le Maroquin F-42820 AMBIERLE, declara que el material nuevo denominado :  
**LEVANO® I Réf. 51.300.0 – Elevador manual utilizado para la colocación de placas de cartón-yeso**  
Está en conformidad con la directiva europea 2006/42/CE del 17 de Mayo de 2006.

Examen de conformidad realizado por SOCOTEC. Acta número 303F0/11/1619  
La presentación de esta declaración de conformidad no exime de sus obligaciones a los usuarios ni a los responsables de los establecimientos usuarios cuando las disposiciones reglamentarias del país en que se instala este producto así lo requieran.

Fait à AMBIERLE, le 7 mars 2011

Le Directeur Général,  
Christophe VALETTE

## A - FITTING INSTRUCTIONS AND DIRECTIONS FOR USE

This device has been designed exclusively for fixing plasterboard panels. Any other use of this equipment is strictly forbidden and no responsibility can then be assumed by the manufacturer.  
 Make sure that this device is not used in open premises which might be exposed to violent winds.  
 The wheels of a LEVPANO® must be on level ground without any major obstacle.  
 Any modification to the arms, including for an use other than that provided for by the manufacturer, is forbidden.  
 Read the indicator plate on the device carefully.

### 1) Fitting the various elements of the LEVPANO®

Proceed with the following operations depending on whether you have a LEVPANO® I or a LEVPANO® II :

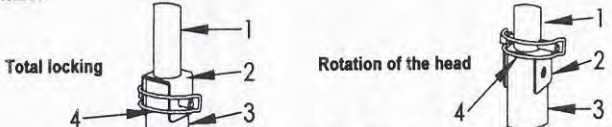
LEVPANO® I Ref. 51.300.0	LEVPANO® II Ref. 51.400.0
- Position the base on the 4 wheels, putting in place the 2 hooks.	- Position the base on the 3 wheels, putting in place the 2 hooks.
- Lock the 2 wheels provided with a brake in order to facilitate the putting in place of the parts	
- Fit the 2 wooden platforms and fix them securely using the 4 screws and the 4 wing-nuts.	
- Position the swivelling and pivoting head at the top of the inner column, adjust the head extension tube according to the fixing height required and then, for total locking of the head with relation to the column, introduce the clips pin, item 4, into the holes corresponding to the 3 elements, items 1, 2 and 3. In order to keep the rotation of the head with relation to the axis of the columns, introduce the clips pin, item 4, only in one of the holes of the extension tube, item 1, and come to rest on the top collar, item 2, of the inner column, item 3.	
	
- Fit the beam in the housing of the swivelling head provided for this purpose, taking care to position the holes located at each end of the beam on the winch side. - Unlock the 4 folding arms which equip the beam, unfold them and lock them using the screws and wing nuts. Fit the crank on the winch (see it note page 11).	

### 2) Adjustment of the folding arms

Depending on the width of the plasterboard panels to be fitted, adjust the 4 folding arms in the corresponding position.

#### 1.20m wide panels

Keep the initial adjustment (A), i.e. the 4 arms deployed and the removable stops fitted on the longest arms.

#### 0.90m wide panels

Keep the removable stops fitted on the longest arms, unlock the shortest 2 arms (B), fold them back, then lock them in the folded position.

#### 0.60m wide panels

Unlock the head and incline it in order to remove the beam, arm and extension assembly from the head.

Turn the beam, arm and extension assembly, rotating it half a turn (C).

Reposition this assembly onto the head of the LEVPANO®.

Remove the 2 removable stops and fit them at the end of the other 2 arms.

Fix the 2 removable stops, using the screws and nuts (D), complying with a clearance of 1 mm when tightening the nut in order to ensure a proper operation of the removable stops (E).

Unlock the longest 2 arms, fold them back, then lock them in this position.

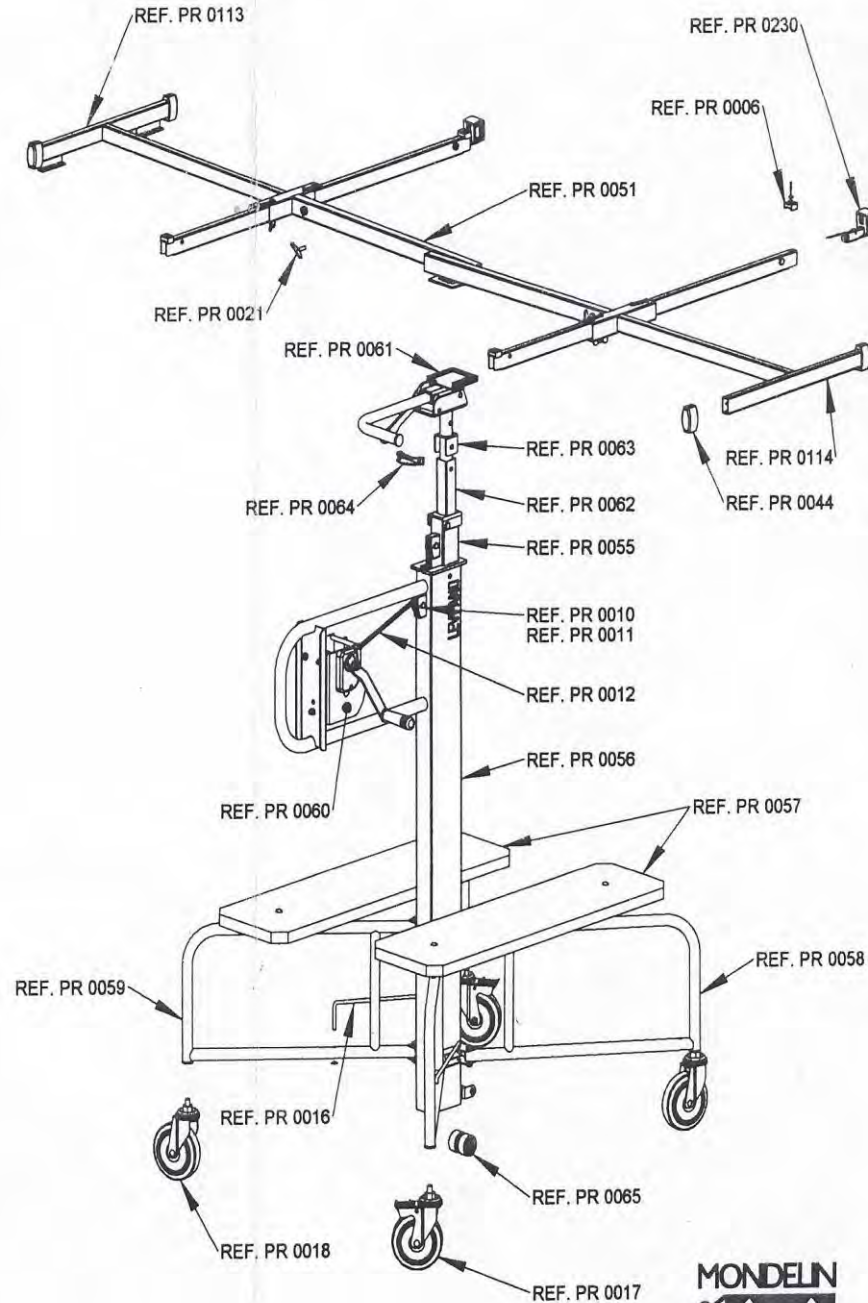
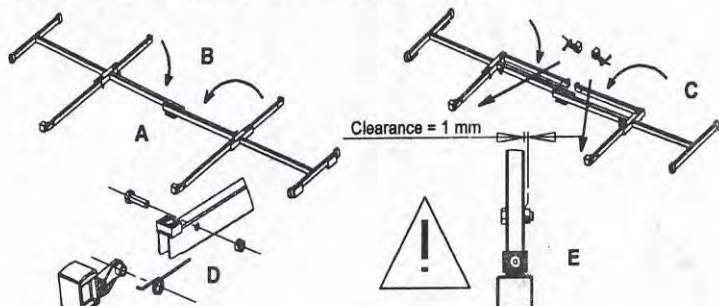

LEVPANO® I  
REF 513000



ENGLISH

- 3) Keep the winch and the crank handle in this position (Clearance = 0), irrespective of the angular position of the handle.
- 4) Fit the lock nut (item 2) onto the pin (item 3)
- 5) Whilst keeping the position of the crank handle in relation to the winch as indicated in paragraph 3, immobilize the pin (item 3) using pliers, or with a 16 mm open-end spanner, and lock the lock-nut (item 2) with a 19 mm open-ended spanner.
- 6) With the assembly correctly fitted, you must have a running clearance between the crank handle (item 1) and the nut (item 2) of about 6 mm.

## D - MAINTENANCE OF THE LEVPANO®

### 1) General maintenance

Check the following parts at regular intervals, according to the indications given in the table below:

PARTS	FREQUENCY		TYPE OF VERIFICATION		
	Week	Month	Visual check	Test	Lubrication
- The condition of the cables, pulleys and pulley pins,		X	X	X	
- The condition of the rubber stops and shoes,	X		X		
- The conditions of the wheels and the operation of the wheel brakes,	X		X	X	
- The fixing and clamping devices		X	X		
- The cleanness of the columns,	X		X	X	
- The condition of the winch and its function (see § 2)	X		X	X	X
- The condition of the head and its function (see § 3)		X	X	X	X

And replace if necessary.

Any defective cable must be replaced by a genuine cable.

Characteristics of the cables: diameter 3 mm, composition: 7 strands of (1 + 6), actual breaking load: 6.22 kN

### 2) Maintenance of the winch :

The winch requires regular servicing by a competent department. Regular cleaning makes for a longer service life.

- Never work with a defective cable.
- Keep the pinions, bearings and reel pin well greased. Use a Molydal N° 3790 type grease.

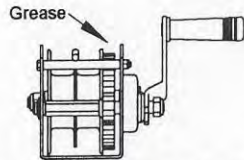

- Keep the winch in good operating condition. Non-serviced mechanical parts can cause operating problems or even accidents.

### 3) Maintenance of the head :

The head requires cleaning at intervals.

Keep the pawl pin well greased. Use a paraffin oil.

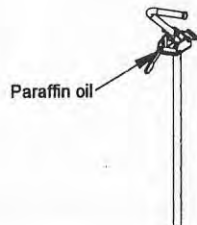

### 3) Adjustment before use

Position the arms to suit the size of the panels but under no circumstances beyond the marks indicated on the 2 sliding arms, maximum opening 3.06 m.

Position the panels so that the load is evenly distributed.

min. change height: 0.82 m.

max. fixing height: 4 m

### 4) Fixing under pitches

For the installation of plasterboards under pitches, unlock the head and incline it in order to swivel the arms around of 90°. Turn the arm extension ref. PR0113 (see page 2 or 37) so that the metal stops are placed upwards to receive the plate.

## B - SAFETY RULES

Make sure that :

LEVPANO® I Réf. 51.300.0

LEVPANO® II Réf. 51.400.0

- The wooden platforms are securely fixed to the chassis,	
- All the elements are perfectly assembled,	
- Nothing impairs the proper working of the LEVPANO®,	
Before lifting a load :	
o Make function the LEVPANO® and check the general state of the device	
o Make absolutely sure that the cables are correctly wound on the winch's drums, and check their position in the groove of the corresponding pulleys.	
o Verify that the cables are parallel to the inside of the columns so as to enable the assembly to work properly.	
o Lock the 2 wheels provided with a brake.	
o Make sure that the columns are clean.	

Do not rotate the winch crank any longer, when the indicator situated at the bottom of the intermediate column appears.

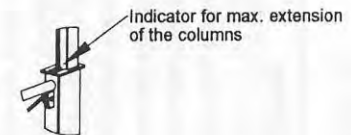

### THE FOLLOWING IS FORBIDDEN :

Do not use the LEVPANO® :

- beyond the maximum use load (75 kg)
- if a cable is broken
- beyond the maximum fixing height, according to the adjustment chosen for the head tube

Do not remain under the load.

When using the LEVPANO®, comply with the work hygiene and safety rules.

## C - FITTING THE WINCH'S HANDLE

NOTE : For reasons of convenience and safety during transport, the winch's handle (item 1) is supplied dismantled, and the lock nut (item 2) fitted on the pin (item 3).

### HANDLE FITTING INSTRUCTIONS

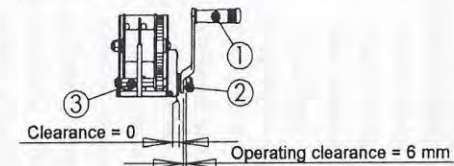

- 1) Remove the lock nut (item 2) from the pin (item 3)
- 2) Take the handle (item 1) and screw it completely on the pin (item 3) (without forcing), so that there is no clearance (See diagram: Clearance = 0).

ENGLISH

## 2) Refitting the cables

- Slide the inner column with the cables inside the intermediate column, then thread the safety and traction cables onto the intermediate column's top pulleys, see drawing below.
- Refit the columns assembly in the LEVPANO®, taking care not to trap the cables (operation "d" to be carried out in the reverse order, see drawing below). Thread the 2 cables onto the pulleys on the complete assembly ref. 3.
- Refit the intermediate column's top collar and fix it with the screw and the nut (operation « c » to be carried out at the time of refitting).
- Refit the 2 cables on the winch's reels, taking care not to cross them, manually pull the 2 cables and fix the cable clamps on their respective cable, making sure they are at the same level to each other, as show on sketch item B. (operation "b" to be carried out in the reverse order). Using the crank handle, wind the cables onto the winch.
- Refit the top collar of the inner column and fit the head. Lock the assembly, using the clips pin.
- Refit the beam, then do a few up and down tests (with no load).

### RECOMMENDATIONS:

- \* Do not overlap the cables when refitting.
- \* Take care to make the position of each part visible before removing it so as to limit the risks or errors.

## G – SCHEMATIC DIAGRAM OF THE PASSAGE OF THE TWO CABLES

Stacking of the columns N° 1 in N° 2 and the whole in N° 3.

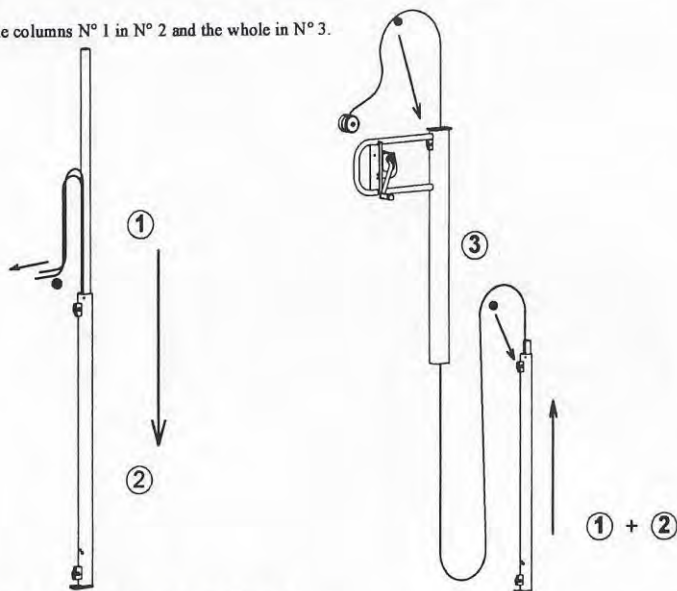

## H – END OF LIFE OF THE PRODUCTS

The metallic parts must be separated from the plastic components in order to ensure recycling in accordance with the regulations in force.

## E – TROUBLESHOOTING GUIDE

If there is apparently a fault on the LEVPANO®, go through the following points before asking for it to be repaired, taking all necessary safety precautions (wear a helmet, goggles and gloves).

If the device is locked in the raised position, make sure that the plasterboard panel is fixed at the ceiling or secure this by means of supports, before attempting to unlock it.

DIFFICULTY	POSSIBLE CAUSE	CORRECTION
Device locked in the raised position	- Brake locked	Undo the crank handle and put it back in contact
	- Cables stuck and/or damaged	Check the passage of the cables and their condition
	- Columns locked	Check the cleanness of the columns
Comes down freely without brake	- Excess winch grease	Degrease the lock washer and the support
	- Tightening of the brake	Put the crank handle and the lock washer in contact
	- Lock washer inoperative	Check the condition of the washer
Goes up with difficulty	- Presence of foreign matter	Clean the device
The device does not lock in the horizontal position	- The pawl remains locked	Clean the pawl pin and grease it with a paraffin oil

### NOTE :

- If the problem persists, contact the After-Sales Department
- For any spare parts order, refer to the exploded view, page 2 for the LEVPANO® I or page 37 for the LEVPANO® II

## F – PROCEDURE FOR CHANGING THE TWO CABLES

### Material required :

- One 8 mm open-ended spanner
- One 10 mm open-ended spanner
- Pliers
- One end-fitting cable spare kit ref. PR 0012 comprising : 2 universal cables and 1 spring.

### 1) Removing the safety and traction cables

- On the LEVPANO® in the working position, remove the central beam and the arms. Remove the head, ref. PR0061 after removing clips pin, then remove the top collar from the inner column.
- Unwind the winch's 2 cables completely (pull on them). The 2 cables are fixed on the winch's reel by means of 2 cable clamps. Remove the 2 cable clamps on the outside of the reel then, using the 8 and 10 mm open-ended spanners, unscrew the 2 cable clamps. The 2 cables are thus released.
- Undo the M8 lock nut and remove the M8 x 65 hex. head screw in order to remove the top collar from the intermediate column and to release the frame columns.
- Take out the inner column ref. 1 and intermediate column ref. 2 assembly (with the cables). Position this assembly horizontally on 2 trestles (see drawing page 14).
- Separate the inner column ref. 1 from the intermediate column ref. 2 (see drawing page 14).
- Remove the worn traction cable from the cable hooking support. Replace the latter with the new cable (see sketch, item A)
- Using pliers, move the spring's loop away so as to disengage the spring from the column. Replace the worn safety cable with the new cable, fixing one of the loops of the new spring to the cable's loop. Fix the other loop of the spring to the column (see sketch, item A)



A

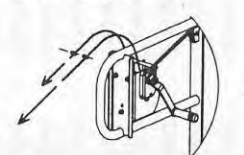

B